



MMC-280 Rev.K 8/03

## 400 Series Standard Control Head Variations

This Service Sheet reflects all current variations of the standard  
 3-detent ZF Mathers 400 Series Control Heads.

### Part Numbering Configurations

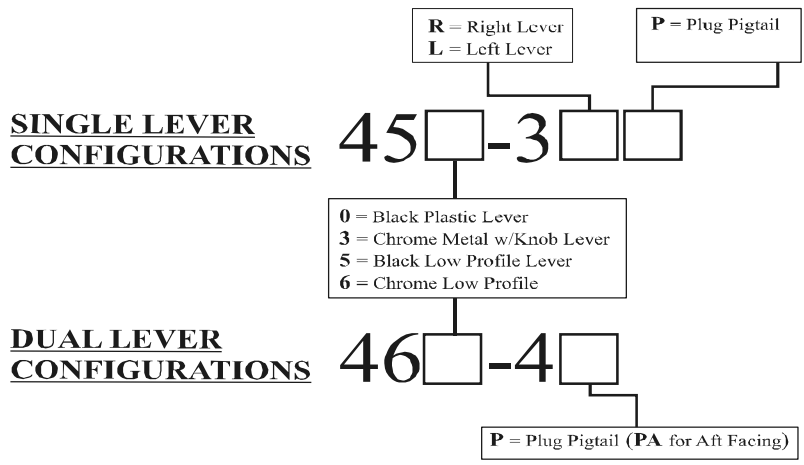

### Detents Available

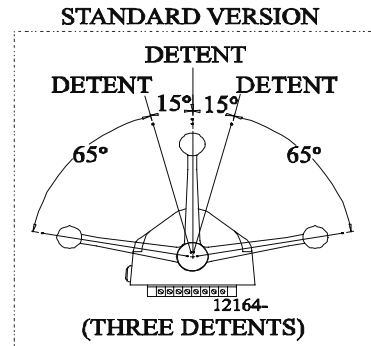

### **REQUIREMENTS:**

- MicroCommander/ClearCommand: one (1) 8-Conductor Cable per Control Head lever.
- Pluggable MicroCommander/ClearCommand: one (1) Control Head Harness per Control Head lever.
- CruiseCommand: one (1) Control Head Harness per Control Head lever.

Included with the Control Head:

- Gasket
- Mounting screws and washers
- Terminals (For 8-Conductor or 1-Connector Harnesses)
- Watertight cable grip for the cable entrance on the Processor (For 8-Conductor)

When the Control Head is properly mounted on a console, it is spray proof from the top only. An adhesive gasket must be used to seal it to the mounting surface. However, below the mounting surface it needs protection from water or spray. Consider using a Weather Mount Enclosure, which is available from ZF Mathers.

### **MOUNTING AND INSTALLATION:**

Select the desired mounting locations and make cutouts per template. Refer to the Dimensions Diagram.

Check that the four mounting screws will start into the Control Head. Remove the Control Head from the cutout.

Remove the backing from the adhesive gasket and apply the gasket adhesive side to the console around the cutout.

Run cable/harnesses between Processor and Control Head. Label both ends with Station it connects (EXAMPLE: Port, Center, or Starboard; Port Thrust, Port Throttle; etc.)

## Dimensions

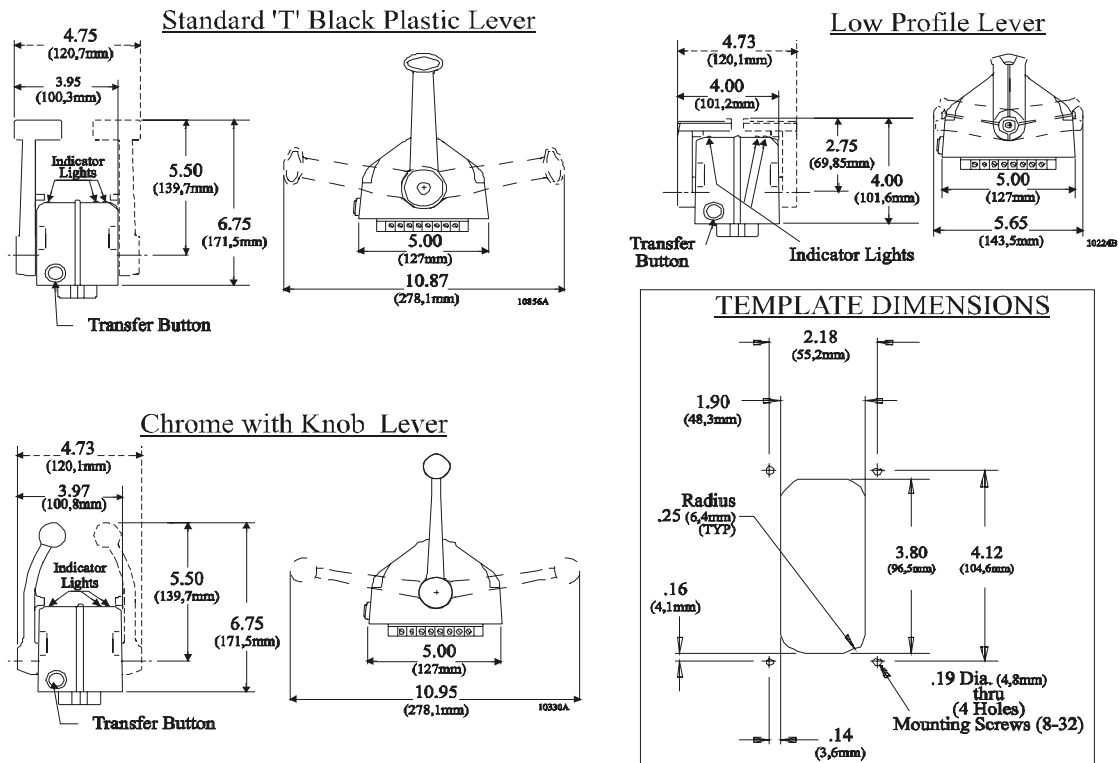

There are two types of Control Head connections available: Plug or Terminal Connected. Both types may be used with MicroCommander, ClearCommand, or CruiseCommand using the appropriate cable or harness. Follow the appropriate steps for the Control Head that has been supplied for your system.

### Standard Cable

Strip back the PVC cover on the shielded cable approximately 2-1/2" (63,5mm) at the Control Head.

At the Control Head end of the cable strip and cut off the shielding and drain wire flush with the end of the PVC cover (the drain wire at the Control Head is not connected to ground).

Strip 3/8" (9,5mm) insulation off each wire.

Twist the individual strands of the wires to minimize fraying.

Crimp a locking fork terminal (included with each Control Head) to each of the conductors.

Make connections to the Control Head as indicated in the following TERMINAL CONNECTIONS diagrams.

### Pluggable

Plug Control Head cable into the pigtail at the Control Head. (Ensure the correct Processor Cable is being plugged into the corresponding Control Head lever pigtail).

When connecting the plugs, ensure that the release button or buttons are depressed and held until plug is fully connected or disconnected. Connecting or disconnecting plugs without depressing and holding the release button or buttons will damage the plug.

ALWAYS REFER TO THE MANUAL THAT IS SUPPLIED WITH THE CONTROL SYSTEM FOR ANY UNIQUE CONTROL HEAD CONNECTIONS FOR YOUR SYSTEM.

When cable connections are complete, MOUNT Control Head to the console using the four (4) mounting screws and washers supplied with the Control Head.

## CABLE/HARNESS CONNECTIONS:

### Dual Control Head Connections

#### TERMINAL CONNECTIONS

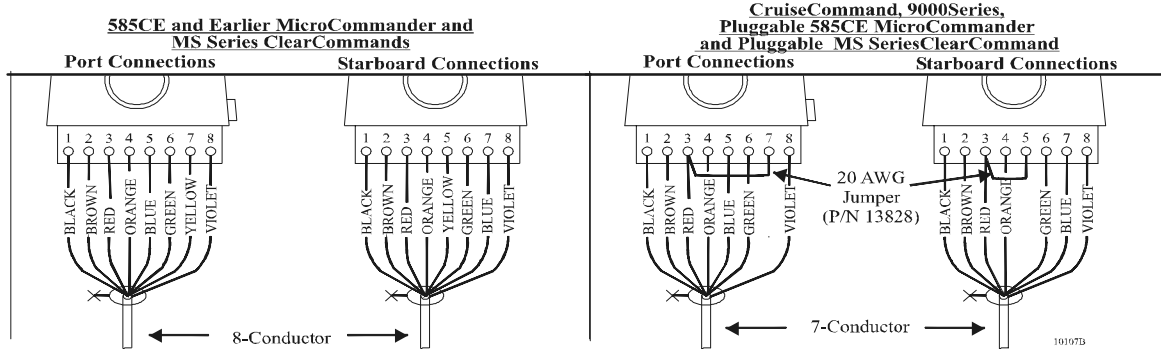

**Cable/Jumper connections 5 and 7 at the Port and Starboard terminal block are direction sensitive.**

#### MicroCommander/ClearCommand

Port Lever:

- Terminal 3 Red
- Terminal 5 Blue
- Terminal 7 Yellow

Starboard Lever:

- Terminal 3 Red
- Terminal 5 Yellow
- Terminal 7 Blue

#### CruiseCommand

Port Lever:

- Terminal 3 Red & JUMPER
- Terminal 5 Blue
- Terminal 7 JUMPER

Starboard Lever:

- Terminal 3 Red & JUMPER
- Terminal 5 JUMPER
- Terminal 7 Blue

#### PLUGGABLE CONNECTIONS

Pluggable Control Heads are supplied with a harness pigtail for each lever. When disconnecting/connecting the plugs, ensure that the release button or buttons are depressed and held until plug is fully disconnected or connected. Disconnecting/connecting plugs without depressing and holding the release button or buttons WILL damage the plug.

### Aft Facing Control Heads

For dual lever Control Head Stations that have the user facing aft:  
Reverse connections 5 and 7.

For single lever Control Head Stations that have the user facing aft and the one Control Head lever on the user's right, reverse connections 5 and 7.

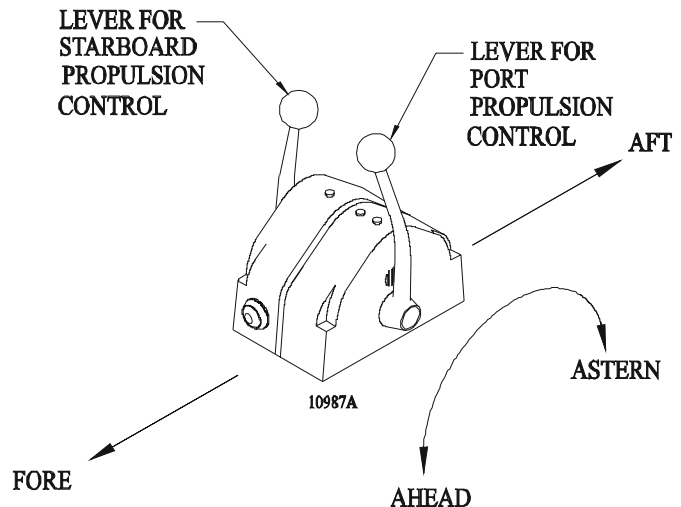

Handheld Control is a Station option. Contact your ZF Mathers Dealer for further information on Handheld requirements and options.



**0.19 Diameter (4,8mm) through Holes  
(4 Holes)**



